



Standard Test Method for One-Dimensional Consolidation Properties of Saturated Cohesive Soils Using Controlled-Strain Loading¹

This standard is issued under the fixed designation D4186/D4186M; the number immediately following the designation indicates the year of original adoption or, in the case of revision, the year of last revision. A number in parentheses indicates the year of last reappraisal. A superscript epsilon (ϵ) indicates an editorial change since the last revision or reappraisal.

1. Scope*

1.1 This test method is for the determination of the magnitude and rate-of-consolidation of saturated cohesive soils using continuous controlled-strain axial compression. The specimen is restrained laterally and drained axially to one surface. The axial force and base excess pressure are measured during the deformation process. Controlled strain compression is typically referred to as constant rate-of-strain (CRS) testing.

1.2 This test method provides for the calculation of total and effective axial stresses, and axial strain from the measurement of axial force, axial deformation, chamber pressure, and base excess pressure. The effective stress is computed using steady state equations.

1.3 This test method provides for the calculation of the coefficient of consolidation and the hydraulic conductivity throughout the loading process. These values are also based on steady state equations.

1.4 This test method makes use of steady state equations resulting from a theory formulated under particular assumptions. Section 5.5 presents these assumptions.

1.5 The behavior of cohesive soils is strain rate dependent and hence the results of a CRS test are sensitive to the imposed rate of strain. This test method imposes limits on the strain rate to provide comparable results to the incremental consolidation test (Test Method D2435).

1.6 The determination of the rate and magnitude of consolidation of soil when it is subjected to incremental loading is covered by Test Method D2435.

1.7 This test method applies to intact (Group C and Group D of Practice D4220), remolded, or laboratory reconstituted samples.

1.8 This test method is most often used for materials of relatively low hydraulic conductivity that generate measurable

excess base pressures. It may be used to measure the compression behavior of essentially free draining soils but will not provide a measure of the hydraulic conductivity or coefficient of consolidation.

1.9 All recorded and calculated values shall conform to the guide for significant digits and rounding established in Practice D6026, unless superseded by this test method. The significant digits specified throughout this standard are based on the assumption that data will be collected over an axial stress range from 1% of the maximum stress to the maximum stress value.

1.9.1 The procedures used to specify how data are collected/recorded and calculated in this standard are regarded as the industry standard. In addition, they are representative of the significant digits that should generally be retained. The procedures used do not consider material variation, purpose for obtaining the data, special purpose studies, or any considerations for the user's objectives; and it is common practice to increase or reduce significant digits of reported data to be commensurate with these considerations. It is beyond the scope of this standard to consider significant digits used in analysis methods for engineering design.

1.9.2 Measurements made to more significant digits or better sensitivity than specified in this standard shall not be regarded a non-conformance with this standard.

1.10 *Units*—The values stated in either SI units or inch-pound units [given in brackets] are to be regarded separately as standard. The values stated in each system may not be exact equivalents; therefore, each system shall be used independently of the other. Combining values from the two systems may result in non-conformance with the standard.

1.10.1 The gravitational system is used when working with inch-pound units. In this system, the pound (lbf) represents a unit of force (weight), while the unit for mass is slugs. The rationalized slug unit is not given, unless dynamic ($F = ma$) calculations are involved.

1.10.2 It is common practice in the engineering/construction profession to concurrently use pounds to represent both a unit of mass (lbm) and of force (lbf). This implicitly combines two separate systems of units; that is, the absolute system and the gravitational system. It is scientifically undesirable to combine the use of two separate sets of inch-pound units within a single standard. As stated, this standard includes the gravitational

¹ This test method is under the jurisdiction of ASTM Committee D18 on Soil and Rock and is the direct responsibility of Subcommittee D18.05 on Strength and Compressibility of Soils.

Current edition approved Nov. 1, 2012. Published December 2012. Originally approved in 1982. Last previous edition approved in 2006 as D4186 – 06. DOI: 10.1520/D4186_D4186M-12.

*A Summary of Changes section appears at the end of this standard

system of inch-pound units and does not use/present the slug unit for mass. However, the use of balances or scales recording pounds of mass (lbm) or recording density in lbm/ft³ shall not be regarded as non-conformance with this standard.

1.11 *This standard may involve hazardous materials, operations, and equipment. This standard does not purport to address all of the safety concerns, if any, associated with its use. It is the responsibility of the user of this standard to establish appropriate safety and health practices and determine the applicability of regulatory limitations prior to use.*

2. Referenced Documents

2.1 ASTM Standards:²

- [D653 Terminology Relating to Soil, Rock, and Contained Fluids](#)
- [D854 Test Methods for Specific Gravity of Soil Solids by Water Pycnometer](#)
- [D1587 Practice for Thin-Walled Tube Sampling of Soils for Geotechnical Purposes](#)
- [D2216 Test Methods for Laboratory Determination of Water \(Moisture\) Content of Soil and Rock by Mass](#)
- [D2435 Test Methods for One-Dimensional Consolidation Properties of Soils Using Incremental Loading](#)
- [D2487 Practice for Classification of Soils for Engineering Purposes \(Unified Soil Classification System\)](#)
- [D2488 Practice for Description and Identification of Soils \(Visual-Manual Procedure\)](#)
- [D3213 Practices for Handling, Storing, and Preparing Soft Intact Marine Soil](#)
- [D3550 Practice for Thick Wall, Ring-Lined, Split Barrel, Drive Sampling of Soils](#)
- [D3740 Practice for Minimum Requirements for Agencies Engaged in Testing and/or Inspection of Soil and Rock as Used in Engineering Design and Construction](#)
- [D4220 Practices for Preserving and Transporting Soil Samples](#)
- [D4318 Test Methods for Liquid Limit, Plastic Limit, and Plasticity Index of Soils](#)
- [D4452 Practice for X-Ray Radiography of Soil Samples](#)
- [D4753 Guide for Evaluating, Selecting, and Specifying Balances and Standard Masses for Use in Soil, Rock, and Construction Materials Testing](#)
- [D5720 Practice for Static Calibration of Electronic Transducer-Based Pressure Measurement Systems for Geotechnical Purposes](#)
- [D6026 Practice for Using Significant Digits in Geotechnical Data](#)
- [D6027 Practice for Calibrating Linear Displacement Transducers for Geotechnical Purposes](#)
- [D6519 Practice for Sampling of Soil Using the Hydraulically Operated Stationary Piston Sampler](#)
- [D6913 Test Methods for Particle-Size Distribution \(Gradation\) of Soils Using Sieve Analysis](#)

D7015 Practices for Obtaining Intact Block (Cubical and Cylindrical) Samples of Soils

3. Terminology

3.1 Definitions:

3.1.1 For definitions of technical terms used in this Test Method, see Terminology [D653](#).

3.2 Definitions of Terms:

3.2.1 *back pressure, $(u_b (FL^{-2}))$* —a fluid pressure in excess of atmospheric pressure that is applied to the drainage boundary of a test specimen.

3.2.1.1 *Discussion*—Typically, the back pressure is applied to cause air in the pore spaces to pass into solution, thus saturating the specimen.

3.2.2 *consolidometer*—an apparatus containing a specimen under conditions of negligible lateral deformation while allowing one-dimensional axial deformation and one directional axial flow.

3.2.3 *excess pore-water pressure, $\Delta_u (FL^{-2})$* —in *effective stress testing*, the pressure that exists in the pore fluid relative to (above or below) the back pressure.

3.2.4 *total axial stress, $\sigma_a (FL^{-2})$* —in *effective stress testing*, the normal stress applied to the axial boundary of the specimen in excess of the back pressure.

3.3 Definitions of Terms Specific to This Standard:

3.3.1 *average effective axial stress, $\sigma'_a (FL^{-2})$* —the effective stress calculated using either the linear or nonlinear theory equations to represent the average value at any time under steady state constant strain rate conditions.

3.3.2 *axial deformation reading, AD (volts)*—readings taken during the test of the axial deformation transducer.

3.3.3 *axial force reading, AF (volts)*—readings taken during the test of the axial force transducer.

3.3.4 *base excess pressure, $\Delta u_m (FL^{-2})$* —the fluid pressure in excess (above or below) of the back pressure that is measured at the sealed boundary of the specimen under conditions of one way drainage. The base excess pressure will be positive during loading and negative during unloading.

3.3.5 *base excess pressure ratio, $R_u (D)$* —the ratio of (1) the base excess pressure to (2) the total axial stress. This value will be positive during loading and negative during unloading.

3.3.6 *base excess pressure reading, BEP (volts)*—readings taken during the test of the base excess pressure transducer when using a differential pressure transducer which is referenced to the chamber pressure.

3.3.7 *base pressure, $u_m (FL^{-2})$* —the fluid pressure measured at the sealed boundary (usually at the base of the consolidometer) of the specimen under conditions of one way drainage.

3.3.8 *base pressure reading, BP (volts)*—readings taken during the test of the base pressure transducer.

3.3.9 *chamber pressure, $\sigma_c (FL^{-2})$* —the fluid pressure inside the consolidometer. In most CRS consolidometers, the chamber fluid is in direct contact with the specimen. For these devices (and this test method), the chamber pressure will be equal to the back pressure.

² For referenced ASTM standards, visit the ASTM website, www.astm.org, or contact ASTM Customer Service at service@astm.org. For *Annual Book of ASTM Standards* volume information, refer to the standard's Document Summary page on the ASTM website.

3.3.10 *chamber pressure reading, CP (volts)*—readings taken during the test of the chamber pressure transducer.

3.3.11 *constant rate-of-strain, CRS*—a method of consolidating a specimen in which the surface is deformed at a uniform rate while measuring the axial deformation, axial reaction force, and induced base excess pressure.

3.3.12 *dissipation*—change over time of an excess initial condition to a time independent condition.

3.3.13 *equilibrated water*—test water that has come to equilibrium with the current room conditions including temperature, chemistry, dissolved air, and stress state.

3.3.14 *linear theory (calculation method)*—a set of equations derived based on the assumption that the coefficient of volume compressibility (m_v) is constant (the soil follows a linear strain versus effective stress relationship).

3.3.15 *monofilament nylon screen*—thin porous synthetic woven fabric made of single untwisted filament nylon.

3.3.16 *nonlinear theory (calculation method)*—a set of equations derived based on the assumption that the compression index (C_c) is constant (the soil follows a linear strain versus log effective stress relationship).

3.3.17 *steady state condition—in CRS testing*, a time independent strain distribution within the specimen that changes in average value as loading proceeds.

3.3.18 *steady state factor, F (D)*—a dimensionless number equal to the change in total axial stress minus the base excess pressure divided by the change in total axial stress.

3.3.19 *transient condition—in CRS testing*, a time dependent variation in the strain distribution within the specimen that is created at the start of a CRS loading or unloading phase or when the strain rate changes and then decays with time to a steady state strain distribution.

3.3.20 *unit conversion factor*—a constant used in an equation to unify the system of units (eg, SI to inch pound) or prefix of variables (eg, cm to m) within the same system of units.

4. Summary of Test Method

4.1 In this test method the specimen is constrained axially between two parallel, rigid boundaries and laterally such that the cross sectional area remains essentially constant. Drainage is provided along one boundary (typically the top) and the fluid pressure is measured at the other sealed boundary (typically the base) of the consolidometer.

4.2 A back pressure is applied to saturate both the specimen and the base pressure measurement system.

4.3 The specimen is deformed axially at a constant rate while measuring the time, axial deformation, reaction force, chamber pressure, and base pressure. A standard test includes one loading phase, one constant load phase, and one unloading phase. The constant load phase allows the base excess pressure to return to near zero prior to unloading. More extensive tests can be performed by including more phases to obtain unload-reload cycle(s).

4.4 The rate of deformation is selected to produce a base excess pressure ratio that is between about 3 % and 15 % at the end of the loading phase.

NOTE 1—The base excess pressure ratio typically decreases during loading. The lower limit provides sufficient pressure to compute the rate parameters and the upper limit reduces the differences between the linear and non linear model calculations. It also helps constrain differences in the compression behavior when testing rate sensitive materials.

4.5 During loading and unloading, the measurements are first evaluated in order to be sure transient effects are small as defined by the steady state factor. Steady state equations are then used to compute the one-dimensional effective axial stress versus strain relationship. During the loading phase, when base excess pressures are significant and transient effects are small, the measurements are used to compute both the coefficient of consolidation and hydraulic conductivity throughout the test.

4.6 It is possible to interpret measurements made during the test when transient effects are significant but these equations are complicated and beyond the scope of this standard test method. Interpretation of transient conditions does not constitute non-conformance of this test method.

5. Significance and Use

5.1 Information concerning magnitude of compression and rate-of-consolidation of soil is essential in the design of earth structures and earth supported structures. The results of this test method may be used to analyze or estimate one-dimensional settlements, rates of settlement associated with the dissipation of excess pore-water pressure, and rates of fluid transport due to hydraulic gradients. This test method does not provide information concerning the rate of secondary compression.

5.2 Strain Rate Effects:

5.2.1 It is recognized that the stress-strain results of consolidation tests are strain rate dependent. Strain rates are limited in this test method by specification of the acceptable magnitudes of the base excess pressure ratio during the loading phase. This specification provides comparable results to the 100 % consolidation (end of primary) compression behavior obtained using Test Method **D2435**.

5.2.2 Field strain rates vary greatly with time, depth below the loaded area, and radial distance from the loaded area. Field strain rates during consolidation processes are generally much slower than laboratory strain rates and cannot be accurately determined or predicted. For these reasons, it is not practical to replicate the field strain rates with the laboratory test strain rate.

5.3 Temperature Effects:

5.3.1 Temperature affects the rate parameters such as hydraulic conductivity and the coefficient of consolidation. The primary cause of temperature effects is due to the changes in pore fluid viscosity but soil sensitivity may also be important. This test method provides results under room temperature conditions, corrections may be required to account for specific field conditions. Such corrections are beyond the scope of this test method. Special accommodation maybe made to replicate field temperature conditions and still be in conformance with this test method.

5.4 Saturation Effects:

5.4.1 This test method may not be used to measure the properties of partially saturated soils because the method requires the material to be back pressure saturated prior to consolidation.

5.5 *Test Interpretation Assumptions*—The equations used in this test method are based on the following assumptions:

5.5.1 The soil is saturated.

5.5.2 The soil is homogeneous.

5.5.3 The compressibility of the soil particles and water is negligible.

5.5.4 Flow of pore water occurs only in the vertical direction.

5.5.5 Darcy's law for flow through porous media applies.

5.5.6 The ratio of soil hydraulic conductivity to compressibility is constant throughout the specimen during the time interval between individual reading sets.

5.5.7 The compressibility of the base excess pressure measurement system is negligible compared to that of the soil.

5.6 *Theoretical Solutions*:

5.6.1 Solutions for constant rate of strain consolidation are available for both linear and nonlinear soil models.

5.6.1.1 The linear model assumes that the soil has a constant coefficient of volume compressibility (m_v). These equations are presented in 13.4.

5.6.1.2 The nonlinear model assumes that the soil has a constant compression index (C_c). These equations are presented in Appendix X1.

NOTE 2—The base excess pressure measured at the boundary of the specimen is assumed equal to the maximum excess pore-water pressure in the specimen. The distribution of excess pore-water pressure throughout the specimen is unknown. Each model predicts a different distribution. As the magnitude of the base excess pressure increases, the difference between the two model predictions increases. At a base excess pressure ratio of 15 %, the difference in the average effective stress calculation between the two models is about 0.3 %.

5.6.2 The equations for the linear case are used for this test method. This test method limits the time interval between readings and the maximum base excess pressure ratio to values that yield similar results when using either theory. However, it is more precise to use the model that most closely matches the shape to the compression curve.

5.6.3 The nonlinear equations are presented in Appendix X1 and their use is not considered a non-conformance with this test method.

5.6.4 The equations used in this test method apply only to steady state conditions. The transient strain distribution at the start of a loading or unloading phase is insignificant after the steady state factor (F) exceeds 0.4. Data corresponding to lower steady state factors are not used in this test method.

5.7 This test method may be used to measure the compression behavior of free draining soils. For such materials, the base excess pressure will be zero and it will not be possible to compute the coefficient of consolidation or the hydraulic conductivity. In this case, the average effective axial stress is equal to the total axial stress and the results are independent of model.

5.8 The procedures presented in this test method assume a high permeability porous disk is used in the base pressure measurement system. Use of a low permeability porous disk or high-air entry (> 1 bar) disk will require modification of the equipment specifications and procedures. These modifications are beyond the scope of this test method and are not considered a non-conformance.

NOTE 3—The quality of the results produced by application of this standard is dependent on the competence of the personnel performing it, and the suitability of the equipment and facilities. Agencies that meet the criteria of Practice D3740 are generally considered capable of competent and objective testing/sampling/inspection/etc. Users of this standard are cautioned that compliance with Practice D3740 does not in itself assure reliable results. Reliable results depend on many factors; Practice D3740 provides a means of evaluating some of those factors.

6. Apparatus

6.1 *Overview*—Fig. 1 presents an overview of the arrangement of components for a device used to perform the constant rate of strain consolidation test. This figure is provided to aid the reader and does not describe any specific device. The figure shows the essential components and one of many possible configurations. Other arrangements meeting the individual component specifications outlined in the following sections are equally acceptable.

6.2 *Electronics*—This test method requires the use of electronic transducers along with the necessary apparatus to energize (power supply) and read (digital multimeter) these transducers. In addition, automatic data acquisition will be necessary to achieve the required reading frequency.

6.2.1 Transducers are required to measure the base pressure (or base excess pressure), the chamber pressure, the axial deformation, and the axial force. Each transducer must meet the accuracy and capacity requirement specified for the particular measurement. The capacity of the force and pressure transducers will depend on the stiffness of the soil and magnitude of the back pressure.

6.2.2 A power supply is required to energize these transducers. The specific type of power supply will depend on the details of the individual transducers. Ideally, all the transducers will operate using the same power supply. Some data acquisition systems provide transducer power.

6.2.3 The calculations presented in this standard assume that the transducers produce a linear normalized voltage output as a function of the parameter being measured as specified in D5720 and D6027. Many other types of transducers exist and are acceptable options for this standard provided that they meet the accuracy and capacity requirements. These transducers may produce current rather than voltage, have non-linear rather than linear outputs, or may not require normalization to the excitation voltage.

6.2.4 *Recording Devices*:

6.2.4.1 A digital multimeter is useful in setting up tests and obtaining zero readings but conducting a test requires far too many readings (frequency and duration) to be collected manually.

6.2.4.2 A data acquisition system is required to collect and store data during the test. The specifications (bit precision and input range) of the data acquisition system must be matched to the individual transducers in order to obtain the capacity

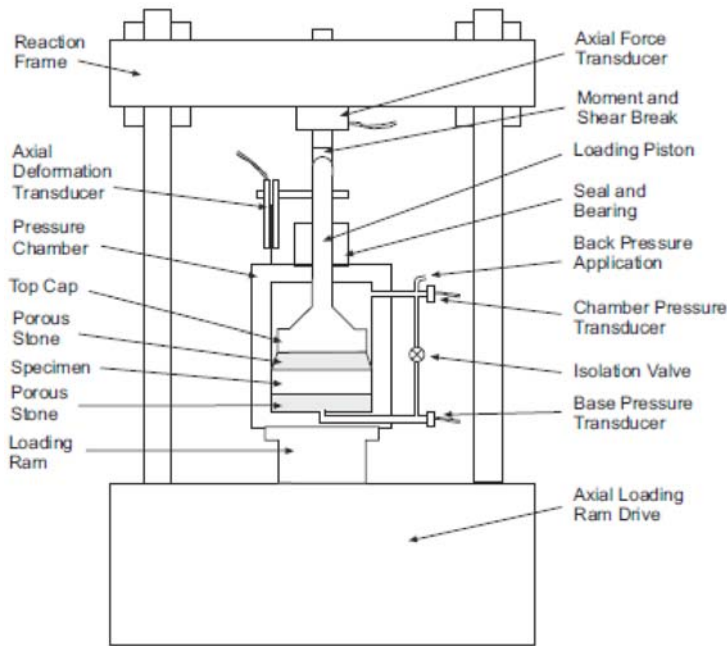

FIG. 1 Overview of Primary Components of a CRS Apparatus

necessary for the individual test and readability requirement for each device. These requirements will depend on the stiffness of the soil, the magnitude of the back pressure, and the output characteristics of the specific transducers.

6.2.4.3 A reading set must contain a measurement of base pressure (or base excess pressure), chamber pressure, axial force, axial deformation, transducer excitation (if using normalized conversion equations), and elapsed time (or time). When determining the hydraulic conductivity or the coefficient of consolidation, time must be recorded to three significant digits of the reading interval and the reading set must be completed within 0.1 s if the measurements are made sequentially. The reading interval will depend on the strain rate.

6.3 *Axial Loading Device*—This device may be a screw jack driven by an electric motor through a geared transmission, a hydraulic or pneumatic loading device, or any other compression device with sufficient force and deformation capacity. It must be able to apply a constant rate of deformation as well as maintain a constant force. During a single loading or unloading phase of the test, the deformation rate should be monotonic and should not vary by more than a factor of 5. The rate can gradually change due to the system stiffness but should not have more than $\pm 10\%$ cyclic variation. During a constant load phase of the test, the load must be maintained to $\pm 2\%$ of the target value. Vibration due to the operation of the loading device shall be considered sufficiently small when there are no visible ripples in a glass of water placed on the loading platform when the device is operating at the typical test speed.

6.4 *Axial Force Measuring Device*—This device may be a load ring, strain-gauge load cell, hydraulic load cell, or any other force-measuring device capable of the accuracy prescribed in this paragraph and may be a part of the axial loading device. The axial force-measuring device shall have an accuracy of 0.25% (or better) of full range and a readability

equivalent to at least 4 significant digits at the maximum force applied to the specimen.

6.4.1 For a constant rate-of-deformation to be transmitted from the axial loading device through the force-measuring device, it is important that the force-measuring device be relatively stiff. Most electronic load cells are sufficiently stiff, while proving rings are typically not stiff (that is, they are compressible).

6.5 *Chamber Pressure Maintaining Device*—This device is used to back pressure saturate the specimen and base pressure measuring system. It must be capable of applying and controlling the chamber pressure to within $\pm 2\%$ of the target pressure throughout the test. This device may consist of a single unit or separate units connected to the top and bottom of the specimen. The device may be a pressurized hydraulic system or a partially filled reservoir with a gas/water interface. The bottom drainage lines shall be connected to the bottom drainage valve and shall be designed to minimize dead space in the lines. This valve, when open, shall permit the application of the chamber pressure to the base of the specimen; when closed, it shall prevent the leakage of water from the specimen base and base pressure measuring device. However, if a high air entry stone is used on the non drainage boundary of the specimen, then different means will be required to keep the system saturated.

6.5.1 A pressurized hydraulic system may be activated by deadweight acting on a piston, a gear driven piston with feedback control, a hydraulic regulator, or any other pressure-maintaining device capable of applying and controlling the chamber pressure within the specifications stated above. The system should be filled with equilibrated test water.

6.5.2 A pressure reservoir partially filled with test water and having a gas/water interface may be controlled by a precision pressure regulator. As much as practicable, the device should minimize the air diffusion into the chamber water. All gas/

water interfaces should be small in area relative to the volume of water in the reservoir and the reservoirs connected to the consolidometer by a length of small diameter tubing. Any water remaining in the reservoir should be flushed out after each test and replenished with equilibrated water.

6.5.3 The bottom drainage valve may be assumed to produce minimum volume change if opening or closing the valve in a closed, saturated pore-water pressure system does not induce a pressure change of greater than 1 kPa [0.1 lbf/in²]. All valves must be capable of withstanding applied pressures without significant leakage.

NOTE 4—Ball valves have been found to provide minimum volume-change characteristics; however, any other type of valve having suitable volume-change characteristics may be used.

6.6 *Chamber Pressure Measuring Device*—A pressure transducer arranged to measure the applied chamber pressure shall have an accuracy of $\pm 0.25\%$ (or better) of full range, a capacity in excess of the applied chamber pressure, and a readability equivalent to at least 4 significant digits at the maximum applied axial stress.

6.7 *Base Pressure Measuring Device*—This device can be a differential pressure transducer referenced to the chamber pressure or a separate pressure transducer measuring pressure at the base of the specimen. If a separate pressure transducer is used, then its zero value must be adjusted to give the same pressure reading as the chamber pressure transducer at the end of back pressure saturation and with the bottom drainage valve open. The device shall be constructed and located such that the water pressure at the base of the specimen can be measured with negligible drainage from the specimen due to changes in pore-water pressure. To achieve this requirement, a stiff electronic pressure transducer must be used. The compliance of all the assembled parts of the base pressure measurement system relative to the total volume of the specimen shall satisfy the following requirement:

$$(\Delta V/V)/\Delta u_m < 3.2 \times 10^{-6} \text{ m}^2/\text{kN} [2.2 \times 10^{-5} \text{ in}^2/\text{lbf}] \quad (1)$$

where:

ΔV = change in volume of the base measurement system due to a pressure change, mm³ [in³],

V = total volume of the specimen, mm³ [in³], and

Δu_m = change in base excess pressure, kPa [lbf/in²].

NOTE 5—To meet this compressibility requirement, tubing between the specimen and the measuring device should be short and thick-walled with small bores. Thermoplastic, copper, and stainless steel tubing have been used successfully.

6.7.1 A differential pressure transducer shall have an accuracy of $\pm 0.25\%$ (or better) of full range, a capacity of at least 50 % of the maximum applied axial stress, a burst pressure that exceeds the applied back pressure plus 50 % of the maximum applied axial stress, and a readability equivalent to at least 4 significant digits at the maximum applied axial stress.

6.7.2 A separate pressure transducer shall have an accuracy of $\pm 0.25\%$ (or better) of full range, a capacity of at least the applied back pressure plus 50 % of the maximum applied axial stress, and a readability equivalent to at least 4 significant digits at the maximum applied axial stress.

NOTE 6—Typically, pressure transducers with a capacity of 1500 kPa [200 lbf/in.²] will meet these requirements.

6.8 *Deformation Measuring Device*—The axial deformation of the specimen is usually determined from the travel of the piston acting on the top platen of the specimen. The deformation measuring device may be a linear variable differential transformer (LVDT), a digital dial gauge (DDG), an extensometer, a linear strain transducer (LST), or other electronic measuring device and shall have a range of at least 50 % of the initial height of the specimen. The device shall have an accuracy of 0.25 % (or better) of full range and a readability of at least 4 significant digits at the initial specimen height.

6.9 *Consolidometer*—This device must hold the specimen in a confinement ring sealed to a rigid base, with porous disks on each face of the specimen and contained within a pressure vessel. The pressure vessel must contain the chamber pressure and provide alignment and a pressure seal for the piston. A high air entry stone can be used in place of the porous disk on the bottom of the specimen provided that the high air entry stone is saturated prior to setting up the specimen. The top platen should be attached to the piston and rigid enough to uniformly distribute the axial load to the top stone. Any potentially submerged parts of the consolidometer shall be made of a material that is noncorrosive in relation to the soil or other parts of the consolidometer. The bottom of the confinement ring shall form a leak proof seal with the rigid base capable of withstanding the base excess pressure. The consolidometer shall be constructed such that placement of the confinement ring (with specimen) into the consolidometer will not entrap air at the base of the specimen. The axial loading device and chamber pressure maintaining device may be an integral part of the consolidometer. A schematic drawing of the essential components of a generic CRS consolidometer is shown in Fig. 2.

6.9.1 *Axial Loading Piston*—The axial loading piston transfers force to the specimen and passes through the pressure vessel.

6.9.1.1 The piston should be constructed of hardened stainless steel with surface roughness and tolerance meeting the specifications set by the bushing manufacturer. The external end of the piston should be concave or convex to mate with the moment break. The internal end should connect rigidly to the top platen.

6.9.1.2 The axial load piston seal must be designed so the variation in axial load due to friction does not exceed 0.05 % of the maximum axial load applied to the specimen.

NOTE 7—The use of two linear ball bushings to guide the piston is recommended to minimize friction and maintain alignment.

6.9.1.3 The external end of the piston should be fitted with a shear and moment break. This element allows precise alignment of the loading piston with the load cell while preventing transfer of either a bending moment or lateral force.

6.9.2 *Specimen Confinement Ring*—The confinement ring shall be made of a material that is noncorrosive in relation to the soil and pore fluid. The inner surface shall be polished and coated with a low-friction material (silicone/vacuum grease). The inside diameter of the ring shall be fabricated to a tolerance of at least 0.1 percent of the diameter.

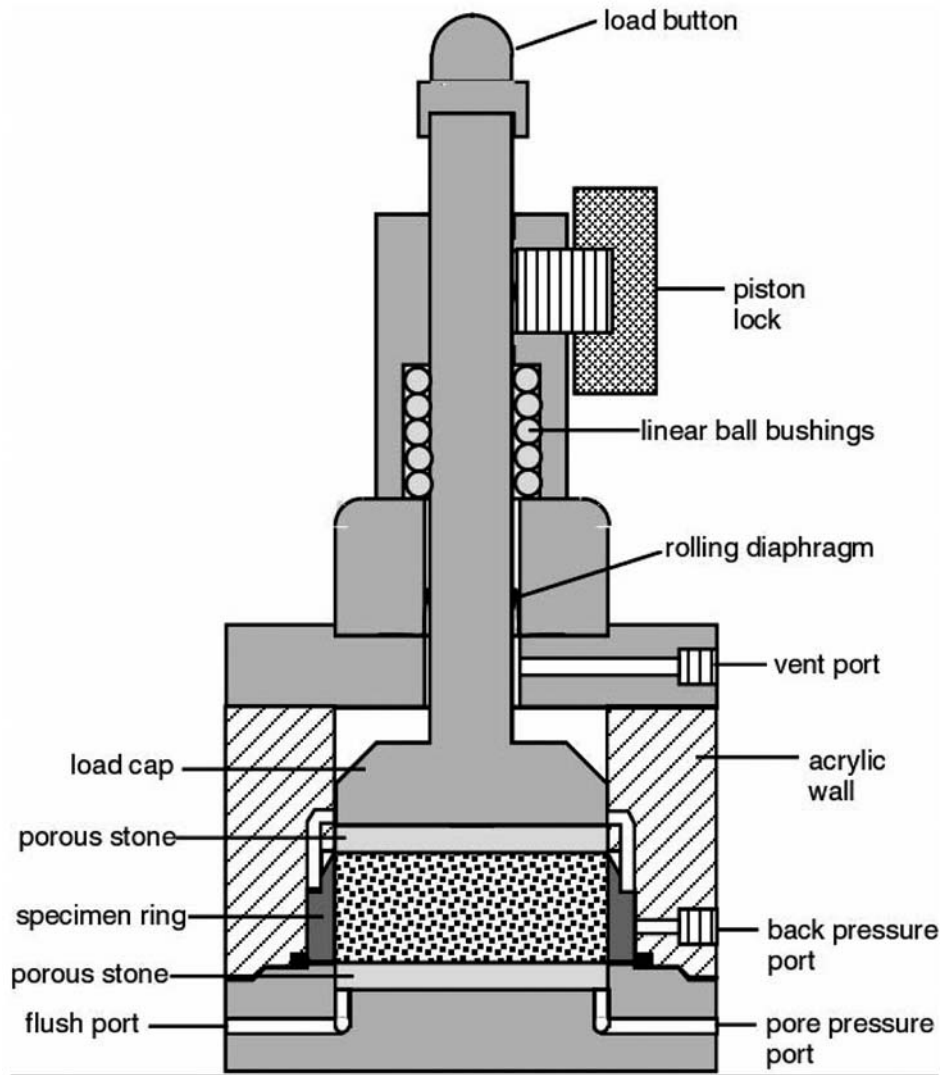

FIG. 2 Example of a CRS Consolidometer

6.9.2.1 *Ring Rigidity*—The ring shall be stiff enough to prevent significant lateral deformation of the specimen throughout the test. The rigidity of the ring shall be such that, under hydrostatic stress conditions in the specimen, the change in diameter of the ring will not exceed 0.04 percent of the diameter under the greatest load applied.

NOTE 8—For example, a ring thickness (for metallic rings) of 3.2 mm [$\frac{1}{8}$ in.] will be adequate for stresses up to 6000 kPa [900 lbf/in²] for a specimen diameter of 63.5 mm [2.5 in.].

6.9.3 *Specimen Geometry*—The test specimen dimensions shall conform to the following specifications.

6.9.3.1 The minimum diameter shall be about 50 mm [2.0 in.].

6.9.3.2 The minimum height shall be about 20 mm [0.75 in.], but shall not be less than 10 times the maximum particle diameter as determined in accordance with Test Method D6913. If, after completion of a test, it is found based on visual

observation that oversize (> 2 mm [0.075 in.]) particles are present, indicate this information in the report of test data.

6.9.3.3 The maximum height-to-diameter ratio shall be 0.4.

6.10 *Porous Disks*—The porous disks at the top and bottom of the specimen shall be made of silicon carbide, aluminum oxide, or other material of similar stiffness that is not corroded by the specimen or pore fluid. The disks shall have plane and smooth surfaces and be free of cracks, chips, and nonuniformities. They shall be checked regularly to ensure that they are not clogged. For fine-grained soils, fine-grade porous disks shall be used. The disks shall be fine enough that the soil will not penetrate into their pores, but have sufficient hydraulic conductivity so as not to impede the flow of water from the specimen. The disk thickness and hydraulic conductivity should result in an impedance factor of at least 100.

NOTE 9—The impedance factor is defined as the ratio of the hydraulic conductivity of the stones times the drainage thickness of the soil to the hydraulic conductivity of the soil times the thickness of the stone.

6.10.1 The diameter of the top disk shall be 0.2 to 0.5 mm [0.01 to 0.02 in.] less than the inside diameter of the confinement ring.

6.10.2 The surfaces of the disks, as well as the bearing surfaces in contact with them, shall be flat and rigid enough to prevent breakage of these disks.

6.10.3 The disks shall be regularly cleaned by ultrasonification or boiling and brushing and checked routinely for signs of clogging. Disks will last longer if stored in water between testing.

6.11 *Filtering Element*—To prevent intrusion of material into the pores of the porous disk, a filtering element must be placed between the top porous disk and the specimen. The element shall have negligibly small hydraulic impedance. A fine monofilament-nylon screen mesh or high grade hardened, low ash filter paper may be used for the filtering element.

NOTE 10—Filtering elements should be cut to approximately the same shape as the cross section of the test specimen. Soak the filter paper, if used, in a container of test water to allow it to equilibrate before testing.

6.12 *Balance*—The balance(s) shall be suitable for determining the mass of the specimen plus the containment ring and for making the water content measurements. The balance(s) shall be selected as discussed in Specification **D4753**. The mass of specimens shall be determined to at least four significant digits.

6.13 *Sample Extruder*—When the material being tested is contained in a sampling tube, the soil shall be removed from the sampling tube with an extruder. The sample extruder shall be capable of extruding the soil from the sampling tube in the same direction of travel that the soil entered the tube and with minimum disturbance of the soil. If the soil is not extruded vertically, care should be taken to avoid bending stresses on the soil due to gravity. Conditions at the time of soil extrusion may dictate the direction of removal, but the principle concern is to avoid causing further sample disturbance.

NOTE 11—Removing the soil from a short section of the tube will reduce the amount of force required to extrude the sample and hence cause less disturbance. This can be done by cutting a section from the tube with a band saw or tube cutter prior to extrusion. When using a tube cutter it will be necessary to provide additional support to prevent ovalization of the tube. This technique is very effective when combined with radiography to nondestructively examine the soil and select test locations.

6.14 *Specimen Trimming Devices*—A trimming turntable or a cylindrical cutting ring may be used for cutting the cylindrical samples to the proper specimen diameter. The cutting ring may be part of the confinement ring or a separate piece that fits on the confinement ring. The cutter shall have a sharp edge, a highly polished surface, and be coated with a low-friction material. Alternatively, a turntable or trimming lathe may be used. In either case, the cutting tool must be properly aligned to form a specimen of the same or slightly larger diameter as that of the confinement ring. The top and bottom surface of the specimen may be rough trimmed with a wire saw. All flat surfaces must be finish trimmed with a sharpened straight edge and shall have a flatness tolerance of ± 0.05 mm [0.002 in.].

6.15 *Recess Spacer*—A disc (usually made of acrylic) used to create a gap between the top of the specimen and the top edge of the confinement ring. The disc should be thick enough to be rigid and larger in diameter than the outside diameter of the confinement ring. One surface of the disc should have a protrusion that is about 0.1 mm [0.005 in.] less than the inside diameter of the confinement ring, a step height of at least 1.2 mm [0.050 in.] and a flatness tolerance of ± 0.03 mm [0.001 in.].

6.16 *Specimen Measuring Device*—The specimen height may be computed from the height of the confinement ring and the recess spacer or measured directly. If applicable, the device to measure the height of the specimen shall be capable of measuring to the nearest 0.01 mm [0.001 in.] or better and shall be constructed such that its use will not penetrate the surface of the specimen. The specimen diameter may be assumed equal to the inside diameter of the confinement ring.

6.17 *Temperature Maintaining Device*—Unless otherwise specified by the requesting agency, the standard test temperature shall be in the range of $22 \pm 5^\circ\text{C}$. In addition, the temperature of the consolidometer, test specimen, and reservoir of pore fluid shall not vary more than $\pm 2^\circ\text{C}$. Normally, this is accomplished by performing the test in a room with a relatively constant temperature. If such a room is not available, the apparatus shall be placed in an insulated chamber or other device that maintains a temperature within the tolerance specified above.

6.18 *Test Water*—Water is necessary to saturate the porous stones, fill the pressure chamber and the back pressure system. Ideally, this water would be similar in composition to the specimen pore fluid. Options include extracted pore water from the field, potable tap water, demineralized water, or saline water. The requesting agency should specify the water option. In the absence of a specification, the test should be performed with potable tap water.

6.19 *Water Content Containers*—In accordance with Test Method **D2216**.

6.20 *Drying Oven*—In accordance with Test Method **D2216**.

6.21 *Miscellaneous Equipment*—Specimen trimming and carving tools such as spatulas, knives, and wire saws, data sheets, and wax paper or polytetrafluoroethylene (PTFE) sheet as required.

7. Calibration

7.1 *Apparatus Constants*—The following information is required to determine the physical characteristics to the specimen.

7.1.1 Measure diameter (D_r) and height (H_r) of the confinement ring to the nearest 0.01 mm [0.001 in.].

7.1.2 The cross sectional area (A) of the specimen may be computed from the inside diameter of the confinement ring to four significant digits in cm^2 [in.^2].

7.1.3 Apply a thin coat of grease to the inside perimeter and measure the mass of the confinement ring plus one filtering element and the recess spacer (M_r) to the nearest 0.01 g.

7.1.4 Measure the thickness of the recess spacer plus one filtering element (T_{rs}) to the nearest 0.01 mm [0.001 in.].

7.2 *Miscellaneous Loading Elements*—Determine the cumulative mass (to the nearest 0.001 kg) of the top porous disk plus any other apparatus components that rest on the specimen and are not counterbalanced by the load frame, M_a .

7.3 *Consolidometer Deflection*—The consolidometer deflects due to both changes in axial load and chamber pressure, referred to as apparatus compressibility. The apparatus compressibility must be subtracted from the measured deformations in order to correctly compute the specimen axial strain.

7.3.1 *Correction due to Axial Load*—During consolidation, the measured axial deformations shall be corrected for apparatus compressibility whenever the equipment deformation exceeds 0.10 % of the initial specimen height. If the correction is warranted at any point during the test, then it should be applied to all measurements throughout the test.

7.3.1.1 Assemble the apparatus with a copper, steel, or aluminum disk of approximately the same size as the specimen, the filtering element and the porous disks.

7.3.1.2 Record readings of the axial deformation (AD_n) and axial force (AF_n) as the axial force is increased from the seating value to its maximum value and then returned to the seating value.

7.3.1.3 Use these data to establish the relationship between apparatus deformation (δ_{af}) in mm [in.] as a function of net force (F_a) in kN [lbf].

7.3.2 *Correction due to Chamber Pressure*—During back pressure saturation, the measured axial deformation shall be corrected for apparatus compressibility whenever the equipment deformation exceeds 0.10 % of the specimen height. If the correction is warranted at any point during the test, then correction should be applied throughout the test.

7.3.2.1 Assemble the apparatus with a copper, steel, or aluminum disk of approximately the same size as the specimen, the filtering element, and the porous disks.

7.3.2.2 Apply a seating net axial force to the calibration disk ($F_{a,o}$) prior to applying any chamber pressure and record the axial displacement (AD_o).

7.3.2.3 Increase the chamber pressure and adjust the net axial force back to the seating value ($F_{a,o}$).

7.3.2.4 Record readings of the axial deformation (AD_n) and the chamber pressure (CP_n) at this point.

7.3.2.5 Repeat steps 7.3.2.3 through 7.3.2.4 until a maximum selected chamber pressure has been reached.

7.3.2.6 Use these data to establish the relationship between apparatus deformation (δ_{ap}) in mm [in.] as a function of chamber pressure (σ_c) in kPa [psi].

7.4 *Piston Uplift Correction*—If the design of the consolidometer is such that chamber pressure affects the axial force measuring device (due to the chamber pressure pushing the piston from the consolidometer), the change in force readings with changes in chamber pressure shall be determined by calibration. This is the piston uplift force.

7.4.1 Assemble the apparatus without a specimen.

7.4.2 Record readings of the axial force (AF_n) and the chamber pressure (CP_n) as the chamber pressure is increased from zero to its maximum value and then returned to zero.

7.4.3 Create a plot of axial force (f) in kN [lbf] versus chamber pressure (σ_c) in kPa [psi].

7.4.4 Compute the effective area of the piston (A_p) in m^2 [in.²] as the slope of this line and the effective piston weight (W_p) in kN [lbf] as the intercept with the force axis.

7.5 *Piston Seal Dynamic Friction*—If the design of the consolidometer is such that the friction in the piston seal affects the axial force measuring device, then the axial force shall be corrected whenever the piston friction exceeds 0.5% of the maximum axial stress applied to the specimen. This is the dynamic friction of the piston seal.

7.5.1 Assemble the apparatus without a specimen and apply a typical chamber pressure used during testing.

7.5.2 Record readings of chamber pressure (CP_n) and axial force (AF_n) while advancing the piston at the typical test displacement rate.

7.5.3 Compute the increment in axial force (Δf_n) as the difference between the measured axial force and the piston uplift force.

7.5.4 Compute the dynamic seal friction force (Δf_s) in kN [lbf] as the average of the increment in axial force.

8. Sampling

8.1 Intact samples having satisfactory quality for testing by this test method may be obtained using sampling procedures and apparatus described by Practices [D6519](#), [D1587](#) and [D3550](#). Specimens may also be trimmed from large intact block samples as obtained using Practice [D7015](#).

8.2 Intact samples shall be preserved, handled, and transported in accordance with the Groups C and D samples described in Practice [D4220](#) or for marine samples as described in [D3213](#).

8.3 Intact samples shall be sealed and stored such that no moisture is lost or gained between sampling and testing. Storage time should be minimized and excessively high (> 32°C) or low (< 4°C) temperatures should be avoided.

8.4 The quality of one-dimensional consolidation test results will diminish greatly with sample disturbance. No intact sampling procedure can assure perfect sample quality. Therefore, careful examination of the intact sample and selection of the highest quality soil for testing is essential for reliable testing.

NOTE 12—Examination for sample disturbance, stones or other inclusions, and selection of specimen location is greatly facilitated by x-ray radiography of the samples as described in Test Method [D4452](#).

9. Specimen Preparation

9.1 All reasonable precautions should be taken to avoid disturbance of the soil caused by vibration, distortion, compression, and fracture. Test specimens and soil processing should be performed in an environment which minimizes the change in water content.

9.2 Remove a section of soil from the sampling tube or block that is about twice the height of the confinement ring.

9.3 *Form Specimen Diameter*—Trim the sample to the inside diameter of the confinement ring using one of the following procedures.

9.3.1 Sampling tubes used to collect intact samples shall be at least 2.5 mm [0.10 in.] larger in each dimension than the specimen dimension except as specified in 9.3.2. Trim away the additional material using one of the following methods.

NOTE 13—The degree of sample disturbance is known to increase towards the perimeter of the tube sample as well as the ends of the sample tube. Therefore, it is better to use larger diameter samples and whenever possible, efforts should be made to stay away from using soil close to the perimeter of the sample. It is also generally better to not to use the material near the ends of the sample tubes.

9.3.1.1 When using a trimming turntable, gradually make a complete perimeter cut, the height of the trimming blade, to reduce the soil diameter to that of the confinement ring. Carefully advance the specimen using the alignment guide into the ring by the height of the blade. Repeat until the procedure until the specimen protrudes from the bottom of the ring.

9.3.1.2 When using a cutting ring, trim the soil to a gentle taper in front of the cutting surface with a knife or wire saw. After the taper is formed around the perimeter of the ring, advance the cutter a small distance to shave off the remaining soil and form the final diameter. Repeat the process until the specimen protrudes from the top of the ring.

9.3.2 Specimens obtained using a sleeve-lined or ring-lined sampler may be used without perimeter trimming, provided they comply with the requirements of Practice D3550. If the liner is used as the confinement ring then it must comply with the requirements of 6.9.2.

9.4 *Form the Specimen Ends*—The top and bottom surfaces of the specimen must be smooth and flat.

9.4.1 Trim the top surface of the specimen to be flat and perpendicular to the sides of the consolidometer ring. For soft to medium soils, a wire saw should be used to rough-cut the surface. For stiff soils and all final surfaces, a straightedge with a sharpened cutting surface should be used to assure flatness.

9.4.2 Place the filtering element on the soil surface. Press the top surface of the soil into the ring using the recess spacer. This gap (recess) at the top of the ring must be made in order to avoid extrusion of the soil from the ring and assure proper alignment of the top porous disk. Once the recess has been made at the top surface, the bottom surface should be trimmed flat and perpendicular to the ring sides using the procedure described in 9.4.1.

9.5 If a small particle is encountered in any surface (sides or ends) being trimmed, it should be removed and the resulting void filled with soil from the trimmings. This information shall be recorded on the data sheet.

9.6 Obtain two or more initial water content determinations of the soil trimmings in accordance with Test Method D2216. If insufficient soil trimmings are available, then use material from the same sample and adjacent to the test specimen.

9.7 Determine the initial moist mass of the specimen by measuring the mass of the confinement ring with the specimen, filtering element and recess spacer (M_{tor}) and subtracting the mass of the confinement ring, filtering element and recess spacer ($M_{to} = M_{tor} - M_r$). This measurement must be to the nearest 0.01 g or better.

9.8 *Specimen Height*—Determine the initial height (H_o) of the specimen to the nearest 0.01 mm [0.001 in.] using either of the following.

9.8.1 Take the average of at least 4 evenly spaced measurements of the specimen height (H_m) using a dial comparator or other suitable measuring device which minimizes penetration into the soil during this measurement and subtract the filtering element thickness ($H_o = H_m - T_{fs}$).

9.8.2 Take the height of the confinement ring minus the recess spacer and the filtering element ($H_o = H_r - T_{rs}$).

9.9 When index properties are desired or specified by the requesting agency, store the remaining trimmings taken from around the specimen and judged to be similar material in a sealed container for determination as described in Section 10.

10. Soil Index Property Determination

10.1 Determination of index properties, such as specific gravity and Atterberg Limits, is an important adjunct to, but not a requirement of this test method. Some organizations refer to these index properties as physical properties. These determinations when specified by the requesting agency should be made on the most representative material possible. When testing uniform materials, all index tests may be performed on adjacent trimmings collected in 9.10. When samples are heterogeneous or trimmings are in short supply, index tests should be performed on material from the test specimen as obtained in 12.17.2, plus representative trimmings collected in 9.10. However, there will not be sufficient soil from the test specimen to meet the minimum sample requirements of all these index tests.

10.2 *Specific Gravity*—The specific gravity (G_s), when required, shall be determined in accordance with Test Method D854 on material as specified in 10.1. The specific gravity determined from another sample judged to be similar to that of the test specimen may be used for calculations in Section 13 whenever an approximate void ratio is acceptable. If the specific gravity is assumed, the assumption shall be based on experience gained from testing similar soils, or select a value ranging between 2.7 and 2.8 with a typical value being 2.76.

10.3 *Atterberg Limits*—The liquid limit, plastic limit and plasticity index, when required, shall be determined in accordance with Test Method D4318 using material from the sample as specified in 10.1. Determination of the Atterberg Limits are necessary for proper material classification, and beneficial in evaluation of test results. Atterberg Limits shall be determined on undried soil unless evidence exists to show that results are not affected by oven drying.

11. Preparation of Apparatus

11.1 Fill the chamber pressure maintaining device and base pressure measuring system with equilibrated test water.

11.2 Connect the chamber pressure transducer and record the zero reading (CP_o).

11.3 Saturate the drainage system by allowing water to flow through the system prior to mounting the specimen.

11.4 Connect the base pressure transducer and record the zero reading (BP_o).

NOTE 14—The sequence of steps of the preparation will depend to some degree on the apparatus. Independent of the sequence of setup it is essential that the same datum (or elevation of the phreatic surface) be used when recording the zero of the base pressure and chamber pressure transducer zero values.

11.5 Place the bottom porous disk in the consolidometer using one of the following three practices.

11.5.1 For non-expansive saturated soils with low affinity for water, use a porous disk that has been saturated by boiling in water for at least 10 min and allowed to equilibrate under room conditions or submerged in an ultrasonic bath for at least 10 min. Place the saturated disk into the base filled with water and use a paper towel to remove excess water from the surface of the stone.

11.5.2 For non-expansive partly saturated soils, use a paper towel to drain the excess water from the disk. Place this damp disk into a dry consolidometer base. The connecting lines to the base can remain filled with water.

11.5.3 For expansive soils, use an air dried porous disk. Place this dry disk into a dry consolidation base. The connecting lines to the base can remain filled with water.

12. Procedure

12.1 Assemble the confinement ring with specimen, top filtering element, and top porous disk in the consolidometer. The moisture condition of the top porous disk and filtering element shall match that used for the bottom porous disk as specified in 11.5.

12.2 Assemble the chamber, lower the piston to contact the top porous disk and lock it in place (if possible).

12.3 Place the consolidometer assembly in the axial loading device.

12.4 Record the zero reading for the force measuring device (AF_o).

12.4.1 Place the load button (moment and shear break) on the piston and align the consolidometer to be concentric with the load frame.

12.4.2 Adjust the axial loading device to contact the piston.

12.5 Set the deformation measuring device to the appropriate starting position and record the zero reading (AD_o).

12.6 Unlock the piston and set the axial loading device to maintain constant seating pressure or maintain a constant specimen height. The seating pressure must prevent swelling but not cause significant consolidation.

NOTE 15—The most appropriate seating pressure depends on the stiffness of the soil. It should be as large as possible to eliminate seating displacement errors yet not so large as to cause consolidation. A reasonable estimate is to use about 10 % of the in situ effective stress or causes about 0.2% axial strain.

12.7 Open the valve connecting the consolidometer chamber to the equilibrated water source and fill the chamber, being careful to avoid trapping air or leaving an air space in the chamber.

NOTE 16—Ideally, but depending on the chamber design, water is flushed through the chamber or pressure measuring system, or both, to eliminate as much as possible air pockets/bubbles. Elimination of air under atmospheric pressure greatly assists in the saturation process. Flushing the water through the system while under a partial vacuum will be much more effective. For partially saturated clays, percolation of

deaired water through the specimen may be necessary to achieve saturation with the available back pressure.

12.8 Saturate the specimen and the base pressure measuring system by applying a back pressure while maintaining either constant seating pressure or constant specimen height. The back pressure may be applied to the chamber (top of specimen) or preferably both the chamber and base pressure measuring system (both ends of specimen). Many procedures have been developed to accomplish saturation. The following procedure is suggested.

NOTE 17—The objective of applying the back pressure is to fill all voids in the specimen and base pressure measuring system with water without undesirable prestressing or compressing of the specimen, or allowing the specimen to swell. The amount of air forced into solution is a function of both time and pressure. In addition, air will go into solution much more readily if deaired water rather than room equilibrated water is used for saturation. Since the total stress effect of the back pressure increment is immediate and the pore water pressure response requires time, the effective stress can increase in the middle of the specimen if the back pressure is applied too fast.

12.8.1 Depending on the back pressure maintaining device, the back pressure may be applied in steps or at a constant rate. The steps must be applied in relatively small increments with adequate time between increments to permit equalization of pore pressure throughout the specimen. Normally, the step size can be increased and the equalization time can be decreased as the back pressure (and hence the degree of saturation) increases. The back pressure rate must be applied slowly enough to allow the pore pressure to react in the center of the specimen.

NOTE 18—A typical starting increment would be equal to the seating pressure. The increments would then be doubled in magnitude into the range from 35 kPa [5 lbf/in.²] to 140 kPa [20 lbf/in.²], depending on the magnitude of the preconsolidation pressure and the specimen saturation. A typical first time increment would be 10 min. When using a constant rate of back pressure application, a typical rate would be to apply the back pressure in several hours. Shorter duration increment times or a faster rate application will be acceptable for higher degrees of saturation or less plastic materials. Longer times and slower rates may be required for high plasticity materials. The required magnitude of back pressure to saturate the system is dependent on the amount of air in the system. Typical values are in the range of 400 to 1000 kPa [60 to 150 psi].

12.8.2 Monitor the specimen response during the back pressuring process. When using the constant seating pressure method, the specimen height should remain nearly constant during saturation. When using the constant height method, the seating pressure should remain nearly constant. If the specimen compresses or the seating pressure decreases then the back pressure increment must be reduced, the time increment increased, or the back pressure application rate decreased to allow pore pressure equalization during the back pressuring process.

12.8.3 Check for sufficient saturation by closing the bottom drainage valve and applying an increment in the chamber pressure. If the base pressure increases rapidly (less than 15 s) to the chamber pressure then it may be assumed that saturation is complete.

12.9 Record the post saturation seating force (AF_s), chamber pressure (CP_s), base pressure (BP_s), axial deformation (AD_s), time (t_s) and transducer excitation (VI_s) when applicable prior to the start of controlled strain loading.

12.10 Close the base drainage valve and check (over about a 5-min interval) that the base pressure reading remains nearly constant.

NOTE 19—This step provides a routine method to check for connection problems in the base pressure measuring system. A leak will result in a continuous decrease (to atmosphere pressure) in the base pressure.

12.11 Select a strain rate that will cause a base excess pressure ratio (R_u) between 3 % and 15 % in the normally consolidated range during the loading phase of the test.

NOTE 20—To achieve an acceptable strain rate, it is good practice to target a base excess pressure ratio value of 5 %. The ratio will usually be higher during the initial stages of loading and then decrease into the normally consolidated range. The ratio may vary throughout the normally consolidated range but seldom by more than a factor of 2. Gradually increasing the strain rate at the start of loading to the target value can help to constrain the ratio. When testing an unfamiliar soil, it is useful to change the strain rate during the first test to find the most appropriate rate. The transient data must be removed after each substantial change in rate.

NOTE 21—For a given specimen height, the excess pore-water pressure depends on the strain rate and hydraulic conductivity, as shown in Eq 24. Experience indicates that a good starting value for the strain rate would be 10 %/h for an MH material (USCS classification system, Practice D2487), 1 %/h for a CL material and 0.1 %/h for a CH material

12.11.1 The rate of strain, computed using Eq 21 should be nearly constant throughout a single loading or unloading phase of the test. However, the rate shall be monotonic and shall not vary by more than a factor of 5 during a single phase of the test. The rate can gradually change to control the base excess pressure ratio or due to the system stiffness but shall not have more than ± 10 % cyclic variation.

12.12 Constant rate of strain testing has three distinct phases; loading (increasing stress), constant load (maintaining stress), and unloading (decreasing stress). An individual test can use a combination of these phases to achieve monotonic loading, loading and unloading, or multiple unload/reload loops. During a loading phase, the stress is increased to achieve a target stress or strain value. The constant load phase is normally performed for a specified period of time to allow the base excess pressure (and hence excess pore-water pressure) to dissipate. During an unloading phase, the stress is decreased to a target stress or strain value. It is preferable to include a constant load phase between each stress reversal to allow the base pressure to dissipate. Unless otherwise specified by the requesting agency, a standard test includes one of each phase.

12.12.1 *Loading*—Apply the axial deformation to produce the axial strain rate selected in 12.11. Record time or elapsed time (t_n), axial deformation (AD_n), axial force (AF_n), chamber pressure (CP_n), base pressure (BP_n), and transducer excitation (VI_n) when applicable at least often enough to have about five sets of readings for each 1 % strain. Continue the loading to the target stress or strain value.

12.12.2 *Unloading*—Apply the axial deformation to produce expansion at about one half the strain rate used during the loading phase of the test. Record time or elapsed time (t_n), axial deformation (AD_n), axial force (AF_n), chamber pressure (CP_n), base pressure (BP_n), and transducer excitation (VI_n) when applicable at least often enough to obtain about five sets of readings for each 1 % strain. Continue to unload to the target stress or strain value. During unloading the base excess pressure will become negative and the chamber pressure must

be sufficiently high to maintain the base pressure greater than the saturation pressure (back pressure required to keep air in solution).

NOTE 22—The same strain-rate may be used for both loading and unloading; however, a larger portion of the unloading data will be lost due to the transient strain condition. In addition, the base excess pressure ratio will be much higher during unloading as compared to loading. If hydraulic conductivity or coefficient of consolidation data are desired during unloading then the unloading rate should be further decreased to achieve the specified base excess pressure ratio.

12.12.3 *Constant Load*—Between stages of loading and unloading, maintain constant axial force to allow the excess pore-water pressure to dissipate. Record time or elapsed time (t_n), axial deformation (AD_n), axial force (AF_n), chamber pressure (CP_n), base pressure (BP_n), and transducer excitation (VI_n) when applicable at the same reading rate as the previous phase of the test. Continue this phase of the test for the specified time or until the base excess pressure has dissipated to nearly zero (about 1% of the total stress). Although secondary compression will occur during this phase of the test, there is no standardized method to calculate the coefficient of the secondary compression.

NOTE 23—The data recording rates are specified to allow enough deformation between readings for the incremental calculations provided in Section 13 to yield the necessary significant digits in each equation. More frequent readings may be desirable to better define the trends in properties but reduce the significant digits of the computed parameters and hence will require additional data processing to eliminate noise.

12.13 At the completion of the test, open the bottom drainage valve and decrease the chamber pressure to atmospheric pressure.

12.14 Lock the piston, remove the axial force and record the final zero readings for the axial force (AF_f), chamber pressure (CP_f), base pressure (BP_f), and transducer excitation (VI_f) when applicable.

12.15 Drain the water from the chamber and remove the consolidometer from the load frame.

12.16 Remove the confinement ring with the specimen from the consolidometer.

12.17 Extrude the specimen (being careful to collect all the material) and determine the dry mass of solids.

12.17.1 If material is not needed for index tests, oven dry the entire specimen (including extraneous material stuck to the confinement ring, filtering element, etc.) according to Test Method D2216 and measure the final dry mass (M_d) to the nearest 0.01 g.

12.17.2 If specimen material is needed for index tests, extrude the specimen from the confinement ring and determine the final moist mass (M_{fp}) to the nearest 0.01 g. Use a representative portion of the specimen to determine the water content (w_{fp}) according to Test Method D2216 except record to 0.01 % and use the remaining undried soil for index tests. Separately collect and obtain the dry mass of any extraneous material (M_{dextr}).

13. Calculations

13.1 *General*—Calculations are only shown using SI units, SD stands for minimum number of significant digits, and FS

stands for full scale. Furthermore, the prefix used for each variable has been chosen based on current practice. Other prefixes are permissible and will require different numerical values for the Unit Conversion Factors. Alternative measurement systems (eg. IP) are also permissible, provided consistency of units is maintained throughout the calculations. See 1.10.1 and 1.10.2 for additional comments on the use of inch-pound units.

13.2 Specimen Properties:

13.2.1 Obtain the dry mass of the specimen, M_d , by direct measurement or when part of the specimen is used for index testing, calculate the dry mass as follows:

$$M_d = \frac{M_{if}}{1 + w_{fp}} + M_{dextr} \quad (2)$$

where:

- M_d = dry mass of specimen, g (4 SD),
- M_{if} = moist mass of specimen after test, g (4 SD),
- M_{dextr} = dry mass of extraneous material collected at end of test, g (same resolution as dry mass), and
- w_{fp} = water content after test, decimal form (nearest 0.0001).

13.2.2 Calculate the initial specimen water content, w_o , as follows:

$$w_o = \frac{M_{to} - M_d}{M_d} \times 100 \quad (3)$$

where:

- w_o = initial water content, percent (nearest 0.01),
- M_{to} = initial moist mass of specimen, g (4 SD), and
- 100 = conversion of water content into a percentage.

13.2.3 Compute the initial dry density, ρ_d , as follows:

$$\rho_d = \frac{M_d}{H_o \times A} \quad (4)$$

where:

- ρ_d = initial dry density of specimen, g/cm³ (4 SD),
- H_o = initial specimen height, cm (4 SD), and
- A = specimen area, cm² (4 SD).

13.2.4 Compute the volume of solids, V_s , as follows:

$$V_s = \frac{M_d}{G_s \rho_w} \quad (5)$$

where:

- V_s = volume of solids, cm³ (4 SD),
- G_s = specific gravity of solids, (4 SD), and
- ρ_w = density of water at 20°C, g/cm³ (0.99821).

13.2.5 Since the cross-sectional area of the specimen is constant throughout the test, it is convenient for subsequent calculations to compute the equivalent height of solids, H_s , as follows:

$$H_s = \frac{V_s}{A} \quad (6)$$

where:

- H_s = equivalent height of solids, cm (4 SD).

13.2.6 Calculate the initial void ratio, e_o , as follows:

$$e_o = \frac{H_o - H_s}{H_s} \quad (7)$$

where:

- e_o = initial void ratio, (nearest 0.001).

13.2.7 Calculate the initial degree of saturation, S_o , as follows:

$$S_o = \frac{G_s w_o}{e_o} \quad (8)$$

where:

- S_o = initial degree of saturation, percent (nearest 0.01).

13.3 Engineering Values:

13.3.1 Calculate the axial deformation, δ_n , at any given time or line of data as follows:

$$\delta_n = \left(\frac{AD_n}{VI_n} - \frac{AD_o}{VI_o} \right) \cdot CF_{ad} \quad (9)$$

where:

- δ_n = axial deformation referenced to the initial specimen height, mm (resolution equivalent to 4 SD of initial height, about 0.005 mm),
- AD_n = axial deformation transducer reading, volts (resolution sufficient to achieve deformation resolution),
- AD_o = axial deformation transducer reading at the start of test, volts (resolution sufficient to achieve deformation resolution),
- VI_n = input voltage reading, volts (4 SD),
- VI_o = input voltage reading at start of test, volts (4 SD), and
- CF_{ad} = axial deformation transducer calibration factor, mm/(volt/volt) (5 SD).

13.3.2 Calculate the chamber pressure, $\sigma_{c,n}$, at any given time or line of data as follows:

$$\sigma_{c,n} = \left(\frac{CP_n}{VI_n} - \frac{CP_o}{VI_o} \right) \cdot CF_{cp} \quad (10)$$

where:

- $\sigma_{c,n}$ = chamber pressure, kPa (resolution equivalent to 4 SD of maximum axial stress),
- CP_n = chamber pressure transducer reading, volts (resolution sufficient to achieve the pressure resolution),
- CP_o = chamber pressure transducer reading at the start of test, volts (resolution sufficient to achieve the pressure resolution), and
- CF_{cp} = chamber pressure transducer calibration factor, kPa/(volt/volt) (5 SD).

13.3.3 Calculate the adjusted base pressure zero reading, BP_{ao} , by equating the back pressure to the chamber pressure at the completion of back pressure saturation as follows:

$$BP_{ao} = \left[\frac{BP_s}{VI_s} - \left(\frac{CP_s}{VI_s} - \frac{CP_o}{VI_o} \right) \times \left(\frac{CF_{cp}}{CF_{bp}} \right) \right] \times VI_s \quad (11)$$

where:

- BP_{ao} = adjusted base pressure transducer zero, volts (resolution sufficient to achieve the pressure resolution),

BP_s = base pressure transducer reading at the end of saturation, volts (resolution sufficient to achieve the pressure resolution),
 CP_s = chamber pressure transducer reading at the end of saturation, volts (resolution sufficient to achieve the pressure resolution),
 VI_s = input voltage reading at end of saturation, volts (4 SD), and
 CF_{bp} = base pressure transducer calibration factor, kPa/(volt/volt) (5 SD).

13.3.4 Calculate the base pressure, $u_{m,n}$, at any given time or line of data as follows:

$$u_{m,n} = \left(\frac{BP_n}{VI_n} - \frac{BP_{ao}}{VI_o} \right) \cdot CF_{bp} \quad (12)$$

where:

$u_{m,n}$ = base pressure, kPa (resolution equivalent to 4 SD of the maximum axial stress),
 BP_n = base pressure transducer reading, volts (resolution sufficient to achieve the pressure resolution), and
 BP_{ao} = base pressure transducer adjusted zero reading from the start of test for a differential transducer or from equation 10 when using a separate base pressure transducer, volts (resolution sufficient to achieve the pressure resolution).

13.3.5 Calculate the axial force, f_n , at any given time or line of data as follows:

$$f_n = \left(\frac{AF_n}{VI_n} - \frac{AF_o}{VI_o} \right) \cdot CF_{af} \quad (13)$$

where:

f_n = axial force, kN (resolution equivalent to 4 SD at the maximum axial stress),
 AF_n = axial force transducer reading, volts (resolution sufficient to achieve the pressure resolution),
 AF_o = axial force transducer reading at the start of test, volts (resolution sufficient to achieve the pressure resolution), and
 CF_{af} = axial force transducer calibration factor, kN/(volt/volt) (5 SD).

13.3.6 Calculate the net axial force, $f_{a,n}$, at any given time or line of data as follows:

$$f_{a,n} = f_n + M_a \times g / 1000 - \Delta f_s + W_p - A_p \cdot \sigma_{c,n} \quad (14)$$

where:

$f_{a,n}$ = net axial force, kN (resolution equivalent to 4 SD at the maximum axial stress),
 M_a = mass of miscellaneous loading elements from calibration in 7.2, kg (0.001),
 g = acceleration due to gravity, 9.8067 m/s²,
 Δf_s = dynamic piston friction from calibration in 7.5 (positive for loading phase and negative for unloading phase, kN (resolution equivalent to 4 SD at the maximum axial stress))
 W_p = effective piston weight from the calibration in 7.4, kN (resolution equivalent to 4 SD at the maximum axial stress),

A_p = effective piston area from the calibration in 7.4, m² (4 SD), and
 1000 = unit conversion factor for force between N and kN.

13.4 Consolidation Characteristics:

13.4.1 Calculate the change in specimen height, ΔH_n , at any given time or line of data as follows:

$$\Delta H_n = (\delta_n - \delta_{af,n} - \delta_{ap,n}) / 10 \quad (15)$$

where:

ΔH_n = change in specimen height, cm (resolution equivalent to 4 SD at initial height),
 δ_n = axial deformation, mm (resolution equivalent to 4 SD at initial height),
 $\delta_{af,n}$ = apparatus compressibility from the calibration in 7.3 which depends on the net axial force, $f_{a,n}$, mm (resolution equivalent to 4 SD at initial height),
 $\delta_{ap,n}$ = apparatus compressibility from the calibration in 7.4 which depends on the chamber pressure, $\sigma_{c,n}$, mm (resolution equivalent to 4 SD at initial height), and
 10 = unit conversion factor between cm and mm.

Subscript n denotes the given time or line of data.

13.4.2 Calculate the specimen height, H_n , at any given time or line of data as follows:

$$H_n = H_o - \Delta H_n \quad (16)$$

where:

H_n = specimen height, cm (4 SD), and
 H_o = initial specimen height, cm (4 SD).

13.4.3 Calculate the void ratio, e_n , at any given time or line of data as follows:

$$e_n = \frac{H_n - H_s}{H_s} \quad (17)$$

where:

e_n = void ratio, (nearest 0.001).

13.4.4 Calculate the axial strain, $\epsilon_{a,n}$, at any given time or line of data as follows:

$$\epsilon_{a,n} = \frac{H_o - H_n}{H_o} \times 100 \quad (18)$$

where:

$\epsilon_{a,n}$ = axial strain, percent (nearest 0.01), and
 100 = conversion of strain into a percentage.

13.4.5 Compute the base excess pressure, $\Delta u_{m,n}$, at any given time or line of data as follows:

$$\Delta u_{m,n} = u_{m,n} - \sigma_{c,n} \quad (19)$$

where:

$\Delta u_{m,n}$ = base excess pressure, kPa (equivalent to 4 SD at the maximum axial stress),
 $u_{m,n}$ = base pressure, kPa (equivalent to 4 SD at the maximum axial stress), and
 $\sigma_{c,n}$ = chamber pressure, kPa (equivalent to 4 SD at the maximum axial stress).

13.4.6 Compute the total axial stress, $\sigma_{a,n}$, at any given time or line as follows:

$$\sigma_{a,n} = \frac{f_{a,n}}{A} \times 10\,000 \quad (20)$$

where:

- $\sigma_{a,n}$ = total axial stress, kPa (equivalent to 4 SD at maximum axial stress),
 $f_{a,n}$ = net force, kN, (equivalent to 4 SD at maximum axial force),
 A = specimen area, cm² (4 SD), and
 $10\,000$ = unit conversion factor for area between cm² and m².

NOTE 24—If applied axial force is measured outside the chamber, the measurement must be corrected to account for the uplift force caused by the back pressure acting on the piston the piston area and piston weight and Eq 14.

NOTE 25—The following equations are all based on incremental calculations between individual readings. As the readings are taken more frequently, the significant digits for the result will decrease and the scatter (noise) will increase. This effect can be reduced by smoothing the measurements prior to the calculations or performing the calculations over larger increments (for example, using $n+2$ and $n-2$). Use Practice D6026 to determine the appropriate number of significant digits to report for each value.

NOTE 26—The linear case assumes that the soil has a constant coefficient of volume compressibility (m_v). The linear theory will be presented in the following section in order to calculate parameters.

13.4.7 Calculate the strain rate, ϵ_n , for each time or line of data as follows:

$$\epsilon_n = \frac{\Delta H_{n+1} - \Delta H_{n-1}}{H_o} \cdot \frac{1}{t_{n+1} - t_{n-1}} \quad (21)$$

where:

- ϵ = strain rate, strain/s (SD will depend on values), and
 t = time, s (3 SD).

Subscript ($n+1$) denotes the next time or line of data and subscript ($n-1$) denotes the previous time or line of data.

13.4.8 Calculate the steady state factor F_n to determine if the transient conditions are small enough to proceed with the steady state equations as follows:

$$F_n = \frac{(\sigma_{a,n} - \sigma_{a,l}) - (\Delta u_{m,n} - \Delta u_{m,l})}{\sigma_{a,n} - \sigma_{a,l}} \quad (22)$$

where:

- F_n = dimensionless value to evaluate importance of transient strain, dimensionless (SD will depend on values).

Subscript l denotes the time or line of data corresponding to the start of the loading or unloading phase.

NOTE 27—The steady state equations are based on time independent strain distributions within the specimen, for any line of data having an F less than 0.4 these equations will be approximate. The magnitude of this error increases as F decreases. This test method ignores all data for which F_n is less than 0.4.

13.4.9 If F_n is greater than 0.4, and during any ‘constant load’ stage of the test then calculate the average effective axial stress, $\sigma'_{a,n}$, at any given time or line of data as follows:

$$\sigma'_{a,n} = \left(\sigma_{a,n} - \frac{2}{3} \Delta u_{m,n} \right) \quad (23)$$

where:

- $\sigma'_{a,n}$ = average effective axial stress, kPa (4 SD at maximum axial stress).

13.4.10 If F_n is greater than 0.4, during any ‘loading’ stage of the test, then calculate the hydraulic conductivity, k_n , for a given time or line of data as follows:

$$k_n = \frac{\epsilon_n \cdot H_n \cdot H_o \cdot \gamma_w}{2 \cdot \Delta u_{m,n}} \times \frac{1}{10\,000} \quad (24)$$

where:

- k_n = hydraulic conductivity, m/s (SD will depend on values),
 γ_w = unit weight of water, at 20°C, kN/m³ (9.7891), and
 $10\,000$ = unit conversion factor for height between cm and m.

13.4.11 If F_n is greater than 0.4, during loading and unloading stages of the test, then calculate the volume compressibility, $m_{v,n}$, for a given time or line of date as follows:

$$m_{v,n} = \frac{\epsilon_{n+1} - \epsilon_{n-1}}{\sigma'_{a,n+1} - \sigma'_{a,n-1}} \times \frac{1}{100} \quad (25)$$

where:

- $m_{v,n}$ = volume compressibility, m²/kN (SD will depend on values), and
 100 = conversion of strain into a decimal format.

13.4.12 If F_n is greater than 0.4, and during any ‘loading’ stage of the test, then calculate the coefficient of consolidation, $c_{v,n}$, for a given time or line of data as follows:

$$c_{v,n} = \frac{k_n}{m_{v,n} \cdot \gamma_w} \quad (26)$$

where:

- $c_{v,n}$ = coefficient of consolidation, m²/s (SD will depend on values).

13.4.13 If F_n is greater than 0.4, then calculate the pore pressure ratio, $R_{u,n}$, for a given time or line of data as follows:

$$R_{u,n} = \frac{\Delta u_{m,n}}{\sigma_{v,n}} \quad (27)$$

where:

- $R_{u,n}$ = pore pressure ratio, dimensionless (SD will depend on values).

13.4.14 If the values of average effective axial stress do not change significantly between consecutive readings, the time interval of the calculations may be increased.

14. Report: Test Data Sheet(s)/Form(s)

14.1 The methodology used to specify how data are recorded on the test data sheet(s)/form(s), as given below, is covered in 1.9.

14.2 Record as a minimum the following general information (data):

14.2.1 Specimen identifying information, such as Project No., Boring No., Sample No., Depth, etc.

14.2.2 Any special selection and preparation process, such as removal of gravel or other materials from the specimen, or identification of their presence (sand pockets).

14.2.3 If the specimen is intact, reconstituted, remolded or trimmed in a specialized manner, provide information on method of reconstitution, remolding, date, time of test, etc.

14.2.4 Soil description and classification in accordance with Practice **D2488** or Test Method **D2487** when Atterberg Limits and percent passing #200 sieve are available. Specific gravity of solids, Atterberg limits, and grain size distribution when available plus source of such data when not measured on test specimen.

14.2.5 Test temperature.

14.3 Record as a minimum the following test specimen data:

14.3.1 Average water content of trimmings.

14.3.2 Initial specimen dry density, water content, void ratio, and degree of saturation.

14.3.3 The measured specific gravity (Test Method **D854**) or assumed value.

14.3.4 The initial mass, initial height, and initial diameter.

14.4 Record as a minimum the following test conditions:

14.4.1 Value of back pressure (u_b), strain ($\epsilon_{a,s}$) and seating pressure ($\sigma'_{a,s}$) at the end of back pressure saturation.

14.4.2 Strain rate(s) during loading and unloading.

14.4.3 Pore pressure ratio (R_u) at the end of last loading phase of test.

14.5 *Consolidation Results:*

14.5.1 Tabulate time or elapsed time, void ratio, axial strain, total axial stress, base excess pressure, chamber pressure, average effective axial stress, volume compressibility, hydraulic conductivity, coefficient of consolidation, strain rate, base excess pressure ratio, and steady state factor F .

14.5.2 Graph of void ratio versus log of average effective axial stress or axial strain versus log of average effective axial stress.

14.5.3 Graph of coefficient of consolidation versus log of average effective axial stress.

14.5.4 Graph of base excess pressure ratio versus log of average effective axial stress.

14.5.5 Graph of log hydraulic conductivity versus void ratio.

14.6 Remarks concerning any departures from the procedure outlined, including special loading sequences.

15. Precision and Bias

15.1 *Precision*—Test data on precision are not presented due to the nature of the soil or rock, or both materials tested by this standard. It is either not feasible or too costly at this time to have ten or more laboratories participate in a round-robin testing program. In addition, it is either not feasible or too costly to produce multiple specimens that have uniform physical properties. Any variation observed in the data is just as likely to be due to specimen variation as to operator or laboratory testing variation.

15.2 Subcommittee D18.05 is seeking any pertinent data from users of these test methods that might be used to make a limited statement on precision.

15.3 *Bias*—There is no accepted reference value for these test methods, therefore, bias cannot be determined.

16. Keywords

16.1 compressibility; compressibility coefficient; CRS; consolidation coefficient; consolidation test; consolidometer; hydraulic conductivity; preconsolidation stress; settlement

APPENDIX

(Nonmandatory Information)

X1. NONLINEAR EQUATIONS

X1.1 *Steady State Factor, F :*

$$F_n = \frac{(\log(\sigma_{a,n} - (\Delta u_{m,n} - \Delta u_{m,l})) - \log \sigma_{a,l})}{(\log \sigma_{a,n} - \log \sigma_{a,l})} \quad (\text{X1.1})$$

X1.2 *Average Effective Axial Stress:*

$$\sigma'_{a,n} = (\sigma_{a,n}^3 - 2 \cdot \sigma_{a,n}^2 \cdot \Delta u_{m,n} + \sigma_{a,n} \cdot \Delta u_{m,n}^2)^{1/3} \quad (\text{X1.2})$$

X1.3 *Coefficient of Consolidation:*

$$c_{v,n} = - \frac{H_o \cdot H_n \cdot \log\left(\frac{\sigma_{a,n+1}}{\sigma_{a,n-1}}\right)}{2 \cdot (t_{n+1} - t_{n-1}) \cdot \log\left(\frac{1 - \Delta u_{m,n}}{\sigma_{a,n}}\right)} \quad (\text{X1.3})$$

X1.4 *Hydraulic Conductivity:*

$$k_n = - \frac{0.434 \cdot \epsilon_n \cdot H_o \cdot H_n \cdot \gamma_w}{2 \cdot \sigma'_{a,n} \cdot \log\left(1 - \frac{\Delta u_{m,n}}{\sigma_{a,n}}\right)} \quad (\text{X1.4})$$

SUMMARY OF CHANGES

Committee D18 has identified the location of selected changes to this test method since the last issue, D4186 – 06. that may impact the use of this test method. (Approved November 1, 2012)

- (1) Limitation to stress range added to section 1.9.
- (2) Clarification of Unit statement in 1.10 and put all IP units in [] throughout standard.
- (3) Addition of reference to **D3213**, **D5720**, and **D6027**.
- (4) Modify definitions in 3.2.4, 3.3.1, 3.3.3, 3.3.4, 3.3.13, 3.3.15, 3.3.16, and 3.3.17.
- (5) Change displacement to deformation in 3.3.1 and throughout.
- (6) Addition of definition in 3.3.5 and 3.3.20.
- (7) Addition of Note 1 and renumber all subsequent notes.
- (8) Allowance for transient calculations in 4.6.
- (9) Add clarification to 5.1.
- (10) Impact of temperature effects in 5.3.
- (11) Additional information added to Note 2.
- (12) Addition of overview and Figure 1 in 6.1.
- (13) Generalize deformation sensors in 6.2.3.
- (14) Add clarification in 6.2.4.3.
- (15) Change load measurement to force measurement in 6.4 and throughout standard.
- (16) Add specification to transducer accuracy in 6.4.
- (17) Change back pressure to chamber pressure in 6.5 and throughout.
- (18) Change potable water to test water in 6.5.2 and throughout.
- (19) Change pressure transducer specification in 6.6.
- (20) Change pressure transducer specification in 6.7.1, 6.7.2, and 6.8.
- (21) Generalize deformation measurement devices in 6.8.
- (22) Add details to consolidometer in 6.9.
- (23) Add specifications to loading piston in 6.9.1.
- (24) Add specifications to confinement ring in 6.9.2.
- (25) Add Note 8.
- (26) Add requirement for porous disks.
- (27) Add Note 9.
- (28) Change filtering screen to filtering element and add description in 6.11 and throughout.
- (29) Clarification on balance specification in 6.12.
- (30) Addition to Note 11.
- (31) Specification of standard test temperature in 6.17.
- (32) Addition of test water specification in 6.18.
- (33) Reorganize calibration Section 7.
- (34) Add measurement of loading elements in 7.2.
- (35) Change specification for correction in 7.3.1 and 7.3.2.
- (36) Add section 7.5 on dynamic piston friction correction.
- (37) Add reference to **D3213** in 8.2.
- (38) Add subsection titles to Section 9.
- (39) Add requirement to 9.3.2.
- (40) Add requirement to 9.5.
- (41) Add Note 14.
- (42) Add clarification to 12.1.
- (43) Add load button placement to 12.4.1.
- (44) Add clarification to Note 15.
- (45) Add guidance to Note 16.
- (46) Add requirement to 12.8.1.
- (47) Add guidance to Note 18.
- (48) Clarify requirement to 12.8.2.
- (49) Add clarification to 12.10.
- (50) Require excitation measurement in 12.9 and throughout for measurement sets.
- (51) Add clarification to Note 19.
- (52) Add clarification to Note 20.
- (53) Change maintaining stress to constant load in 12.12. and throughout.
- (54) Change requirement in 12.12.1.
- (55) Add clarification to Note 22.
- (56) Add specification to 12.12.3.
- (57) Add clarification to Note 23.
- (58) Add clarification to 12.13.
- (59) Add instruction to 12.17.2.
- (60) Allowance for other than SI units in 13.1 and description of usage of Unit Conversion Factors.
- (61) Change to equation in 13.2.1.
- (62) Addition of 13.2.3 and renumbering of remaining equations.
- (63) Specification of density of water in 13.2.3.
- (64) Modification to resolution requirements in 13.3.1 and 13.3.2.
- (65) Addition of equation and section 13.3.3.
- (66) Modification of equation and resolutions in 13.3.4.
- (67) Modification of resolutions in 13.3.5.
- (68) Change equation and clarification of terms in 13.3.6.
- (69) Change equation and resolutions in 13.4.1.
- (70) Clarification of resolutions in 13.4.5.
- (71) Add area definition in 13.4.6.
- (72) Add clarification to Note 24.
- (73) Allow effective axial stress calculation during constant load stage in 13.4.9.
- (74) Limit permeability calculation to loading stage of test in 13.4.10.
- (75) Specification of unit weight of water in 13.4.10.
- (76) Allow calculation during loading and unloading stages of test in 13.4.11.
- (77) Limit calculation to loading stage of test in 13.4.12.
- (78) Renumber subsections in 14.
- (79) Add reporting of temperature in 14.2.5.
- (80) Addition of new Figure 1.
- (81) Renumber Figure 1 to Figure 2.
- (82) Correct equation X1.1.
- (83) Correct equation X1.3.
- (84) Correct equation X1.4.
- (85) Numerous editorial corrections and minor clarifications throughout document.



ASTM International takes no position respecting the validity of any patent rights asserted in connection with any item mentioned in this standard. Users of this standard are expressly advised that determination of the validity of any such patent rights, and the risk of infringement of such rights, are entirely their own responsibility.

This standard is subject to revision at any time by the responsible technical committee and must be reviewed every five years and if not revised, either reapproved or withdrawn. Your comments are invited either for revision of this standard or for additional standards and should be addressed to ASTM International Headquarters. Your comments will receive careful consideration at a meeting of the responsible technical committee, which you may attend. If you feel that your comments have not received a fair hearing you should make your views known to the ASTM Committee on Standards, at the address shown below.

This standard is copyrighted by ASTM International, 100 Barr Harbor Drive, PO Box C700, West Conshohocken, PA 19428-2959, United States. Individual reprints (single or multiple copies) of this standard may be obtained by contacting ASTM at the above address or at 610-832-9585 (phone), 610-832-9555 (fax), or service@astm.org (e-mail); or through the ASTM website (www.astm.org). Permission rights to photocopy the standard may also be secured from the ASTM website (www.astm.org/COPYRIGHT/).